

MAGIGLO® SERIES

INSTALLATION & OPERATING MANUAL

This Magiglo series of original 320 and 360 decorative fires are suitable to be installed as a type 1 installation into a masonry or approved prefabricated fireplace and are designed to operate with Natural gas only.
Approval Number 6094 G

VERSION 17

WARRANTY INFORMATION

The benefits provided to you under the following warranty are in addition to any other rights and remedies available to you under the law.

1. Warranty

If:

- (a) during the first 15 years from the date of purchase (Firebox Warranty Period), there is a defect in the firebox of the Gas Burner; or
- (b) during the first 2 years from the date of purchase (Parts Warranty Period), there is a defect in the gas valves or other parts of the Gas Burner,
due to improper workmanship or material, Glen Dimplex will replace or repair the Gas Burner without charge. Any replacement product is warranted only for the time remaining on the original Firebox Warranty Period or the Parts Warranty Period as relevant.

2. Registration

You must register to receive the benefit of this warranty by completing the warranty registration on our website (www.realfame.com.au) or completing and mailing the attached registration card within 30 days of purchase of your Gas Burner (or, if the Gas Burner is fitted to a new home, within 30 days of the date of settlement of purchase of such new home).

3. Exclusions

Glen Dimplex is not obliged to replace or repair the Gas Burner under clause 1 if:

- (a) it has been improperly stored, installed, connected, used, operated or repaired, or damaged, abused, tampered with, altered (without our written approval), or not maintained in strict accordance with our installation and operating instructions; or
- (b) it has been installed in an outdoor setting.

4. Limit of Liability

The warranty provided under this warranty is limited to replacement or repair of the Gas Burner only, at our option. To the extent permitted by law, Glen Dimplex excludes liability for consequential loss or any other loss or damage caused to property or persons arising from any cause whatsoever, and damage arising from normal wear and tear.

5. Claiming under the Warranty

In order to claim under this warranty you must, within the Firebox Warranty Period or the Parts Warranty Period (as relevant), contact Glen Dimplex, providing the original proof of purchase and the details below:

Supplier Name _____

Date Of Purchase / settlement of property if new home _____

Model / Serial Number _____

This warranty does not cover the cost of claiming under the warranty or transporting the Gas Burner to and from the supplier.

Our goods come with guarantees that cannot be excluded under the Australian Consumer Law. You are entitled to a replacement or refund for a major failure and for compensation for any other reasonably foreseeable loss or damage. You are also entitled to have the goods repaired or replaced if the goods fail to be of acceptable quality and the failure does not amount to a major failure.

If you would like to speak to someone about your Gas Burner or claiming under this warranty, please contact the Service Warranty Desk on 1300 554 155.

Glen Dimplex Australia Pty Ltd ACN 69 118 275 460
Head Office: 1340 Ferntree Gully Road, Scoresby 3179
Telephone: (03) 8706 2000 Facsimile: (03) 876 2001

INSTALLATION NOTICE

- The installation of this appliance is only to be carried out by an authorised person in accordance with the Manufacturer's Instructions, local gas fitting regulations, AS/NZS5601.1-2013 installation code for gas burning appliances and any other relevant statutory regulations.
- In all cases the installation of this appliance shall meet the requirements as set out in AS/NZS5601.1-2013

- NOTE: A slight smell may be apparent for the first few hours of use. This is due to the heat resistant paint curing. It is recommended to open windows in the room for the first lighting of the fire. In some instances a slight discolouration may occur inside the firebox. This is a normal condition and is not covered by warranty.

IMPORTANT SAFETY NOTICES

- DO NOT PLACE ARTICLES ON OR AGAINST THIS APPLIANCE.
- DO NOT USE OR STORE FLAMMABLE MATERIAL NEAR THE APPLIANCE.
- DO NOT SPRAY AEROSOLS IN THE VICINITY OF THIS APPLIANCE WHILST IT IS IN OPERATION.
- CARE MUST BE TAKEN TO ENSURE THAT ANY RETURN AIR REGISTER OR EXHAUST SYSTEM DOES NOT ADVERSLEY AFFECT THE OPERATION OF THE APPLIANCE OR DRAUGHT OF CHIMNEY OR FLUE.
- DO NOT MODIFY THIS APPLIANCE.
- THIS APPLIANCE IS DESIGNED TO OPERATE WITH LUMINOUS FLAMES. THIS MAY EXHIBIT SLIGHT CARBON DEPOSITS.

VENTILATION REQUIREMENTS

Permanent ventilation of the room where the fire is to be situated is essential while fire is in operation. The room must have a minimum cross sectional area of 40,000sq mm of effective ventilation.

It is recommended that you service your gas fire every 2 years.

WARNING

This firebox has a naked flame, care should be taken when it is operating if children or the infirm are in close proximity. For protection of young children or the infirm, a secondary guard is required. A safety screen is recommended if constant supervision is not possible. It is recommended that a secondary guard complying with AS-NZS2286 be installed.

The appliance is not intended for use by persons (including children) with reduced physical, sensory or mental capabilities, or lack of experience and knowledge, unless they have been given supervision or instruction concerning use of the appliance by a person responsible for their safety. Children should be supervised to ensure that they do not play with the appliance.

CONTENTS

Contents	4
Data Plate	5
Dimensions	5
Installation Instructions	6
Lighting Instructions.....	7
Commissioning Procedure	8
Typical Type 1 Installation to existing chimney	9
Type 1 Installation into Victorian/Federation grate	10
Typical Type 2 Installation of Prefabricated Fire Box into existing chimney.....	11
User Instructions.....	12
Troubleshooting	12
Conversion details	13
Parts List.....	14
Glen Dimplex contact information	16

DATA PLATE (Affixed to the base of the unit for reference to gas pressure & consumption)

BURNER MODEL	NATURAL GAS		
	INJ. SIZE	MJ/Hr	TPP (kPa)
320	2.40	24	0.80
360	2.50	26	0.80

DIMENSIONS

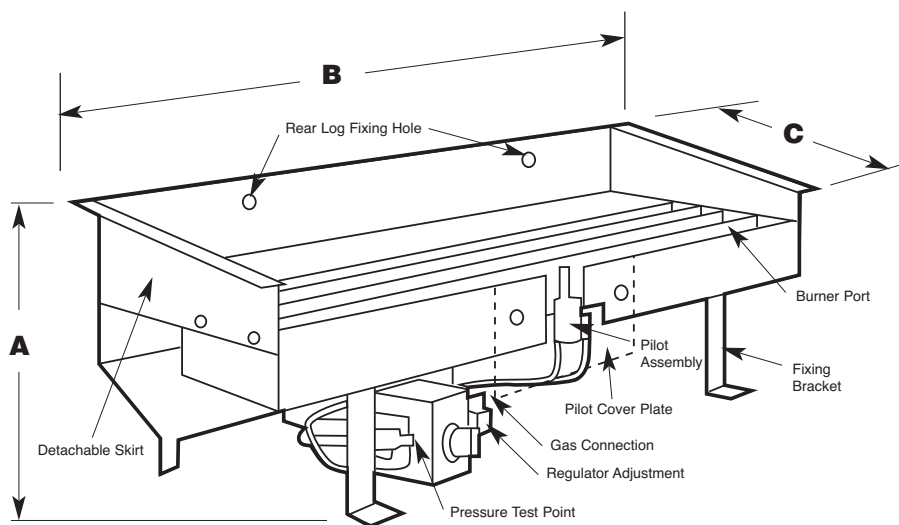

Model	A	B	C
320	165	320	120
360	165	360	120

INSTALLATION INSTRUCTIONS

IMPORTANT

This product is fitted with an **OXYGEN DEPLETION SYSTEM** which is an **INTEGRAL PART OF THE PILOT**. You must maintain the correct pressure for the oxygen depletion system to operate correctly (see data plate on page 5).

When checking gas pressure at the appliance ALL OTHER GAS APPLIANCES IN PREMISES MUST BE OPERATING AT THE SAME TIME.

Failure to have correct pressure may result in unit cutting out intermittently.

TYPE OF INSTALLATIONS

TYPE 1. Magiglo Gas Log/Coal Set

The appliance must be installed in a fire resistant fireplace with approved draft.

TYPE 2. Magiglo Gas Log/Coal Set

Installed in conjunction with a prefabricated firebox into an existing fireplace using the firebox flue system to remove waste products.

LOCATION REQUIREMENTS FOR TYPE 1 INSTALLATIONS

1. The fireplace must be built in accordance with the building regulations for masonry chimneys.
2. The fireplace must be sufficiently deep enough to fully accommodate either the Gas Log/Coal Set or a firebox fitted with a Gas Log/Coal Set in order that no fumes can escape into the room. **DO NOT** ignore the depth of the lintel over the fireplace opening.
3. It is imperative that the chimney or flue operates correctly and also does not subject the living area to spillage of combusted products. The flue or chimney should be tested and proven to have an adequate updraught sufficient to remove all waste products of combustion. (Refer to Commissioning Procedure).
4. Chimney dampers, baffles or restrictive plates must be removed or permanently fixed open.
5. Permanent ventilation of the room where the fire is to be situated is essential while fire is in operation. The room must have a minimum cross sectional area of 40,000sq mm of effective ventilation.
6. Packaging and transit protection must be removed from the appliance prior to installation. This includes pallet, plastic wrap, temporary labels and foam protection.

BURNER INSTALLATION

1. Select the Magiglo series burner which best compliments your fireplace size.
2. Locate your gas fire into the rear of the fireplace or prefabricated fire box fixing to base or grate by location lugs on burner.
3. It is preferable for the gas line to be brought into the rear of fireplace, therefore concealing pipe work.
4. If installing the burner into an existing grate, remove that part of base of grate so that controls are on underside of grate.
5. Connect gas line to burner connection using 1/2" flared copper union supplied.
6. The correct logs and coals or pebbles must be used as supplied by the manufacturer.

FOR YOUR SAFETY READ BEFORE LIGHTING

- The appliance has a pilot which must be lit using the piezo ignition, when lighting the pilot follow the instructions exactly.
- Before lighting the appliance check for gas leaks.
- Use only your hand to push in and turn the gas control knob, never use tools. If the knob will not push in or turn by hand, don't try to repair it, call a qualified service technician. Force or attempt to repair may result in a fire or explosion.
- If the controls have been underwater, immediately call a qualified service technician to inspect the appliance and replace any part of the control system and fan that has been immersed in water.

LIGHTING INSTRUCTIONS - Magiglo 320 & 360

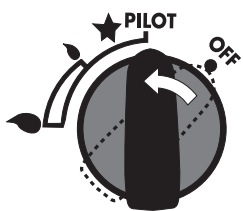

Figure 1

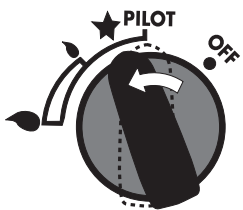

Figure 2

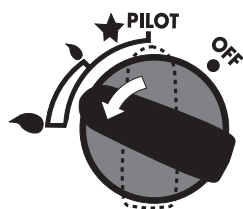

Figure 3

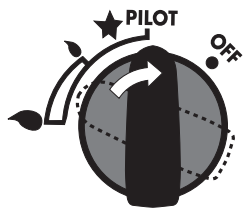

Figure 4

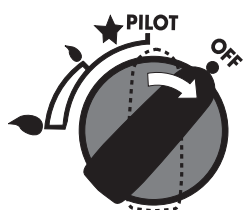

Figure 5

1. To light the pilot, press in and turn the gas control knob anticlockwise to the pilot position.
2. Keep knob depressed and turn the knob anticlockwise toward the ★ until you hear a click. If the pilot lights, continue to depress knob for 20 seconds and release. If pilot goes out repeat the procedure.
3. To light the burner, turn the control knob to the flame setting. The burner can be set anywhere between low and high flame.
4. To turn the burner off, turn the control knob clockwise to the "PILOT" position. This will leave the pilot burning.
5. To turn off the burner and the pilot, turn the knob clockwise to the "OFF" position.

If you are unable to get the appliance to operate correctly, contact either your sales agent or the manufacturer (see contact details on back cover).

Test operation of appliance and fully instruct user before leaving.

Note: Check gas pressure. Refer to Data Plate on page 4 for details.

TO TURN OFF GAS TO APPLIANCE

Push in gas control knob slightly and turn to the "OFF" position.

COMMISSIONING PROCEDURE

Once the fire is installed and operational the installer must check for spillage. Carry out the lighting procedure and turn the fire to high. Allow to warm up for 10 minutes and then using a smoke match set 25mm down and 25mm inside of the fire opening run the match across the width of the opening to check that all of the smoke is drawn away.

Repeat the test with doors and windows to the premises open and closed, and with any extractor fans in the same room or adjacent rooms running on high. The fire should continue to clear its combustion products. Also operate any other flued appliances in the same or neighbouring rooms and ensure they continue to function satisfactorily as multiple flues can work against one another.

If spillage is detected during this procedure it could indicate a faulty flue or lack of ventilation. If the problem cannot be rectified immediately, disconnect the appliance, and advise the customer not to use the appliance until the problem has been resolved.

The customer should always be advised of the need for regular servicing and checks to ensure the continued clearance of combustion waste products.

NOTE: Care must be taken to ensure that any return air register exhaust system does not adversely affect the operation of the appliance or draught of chimney or flue.

WARNING

“DO NOT place articles on or against this appliance.”

“DO NOT use or store flammable materials near this appliance.”

“DO NOT spray aerosols in the vicinity of this appliance while it is in operation.”

TYPICAL TYPE 1 INSTALLATION TO EXISTING CHIMNEY

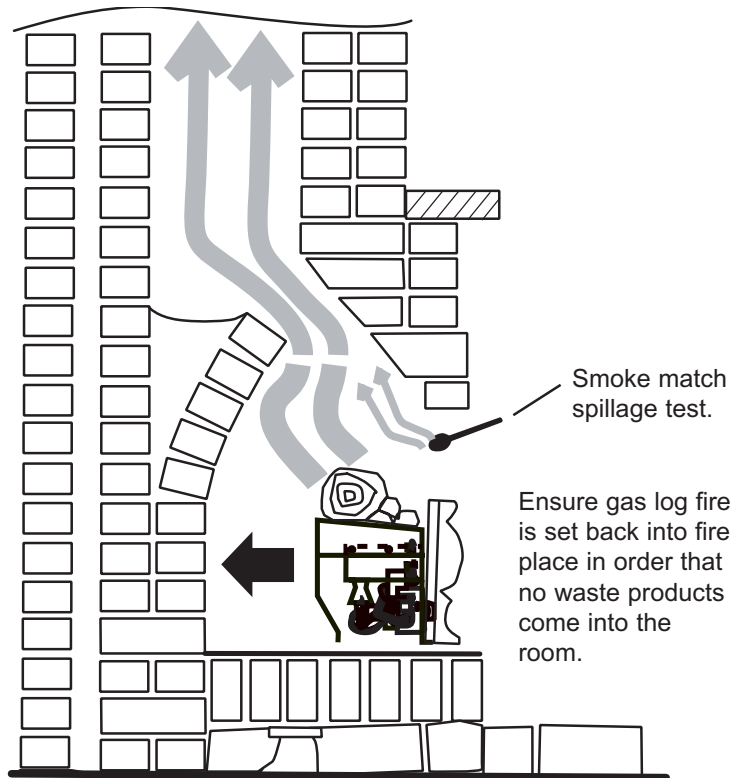
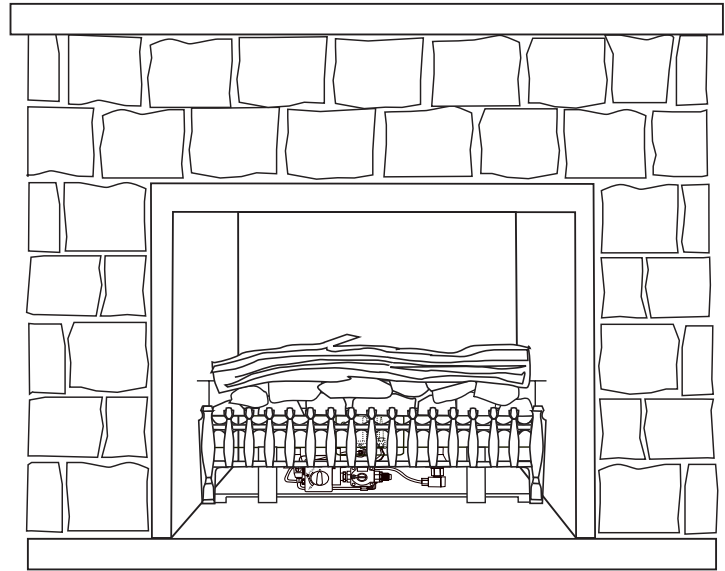
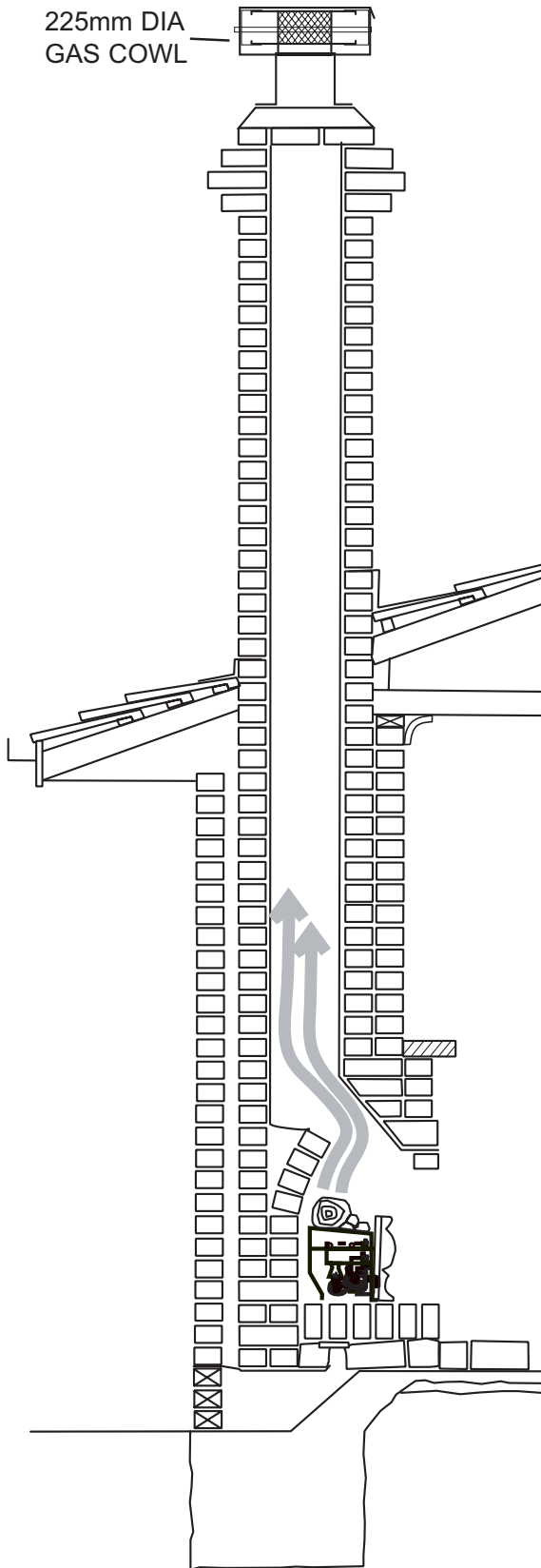

TYPE 1 INSTALLATION INTO VICTORIAN/FEDERATION GRATE

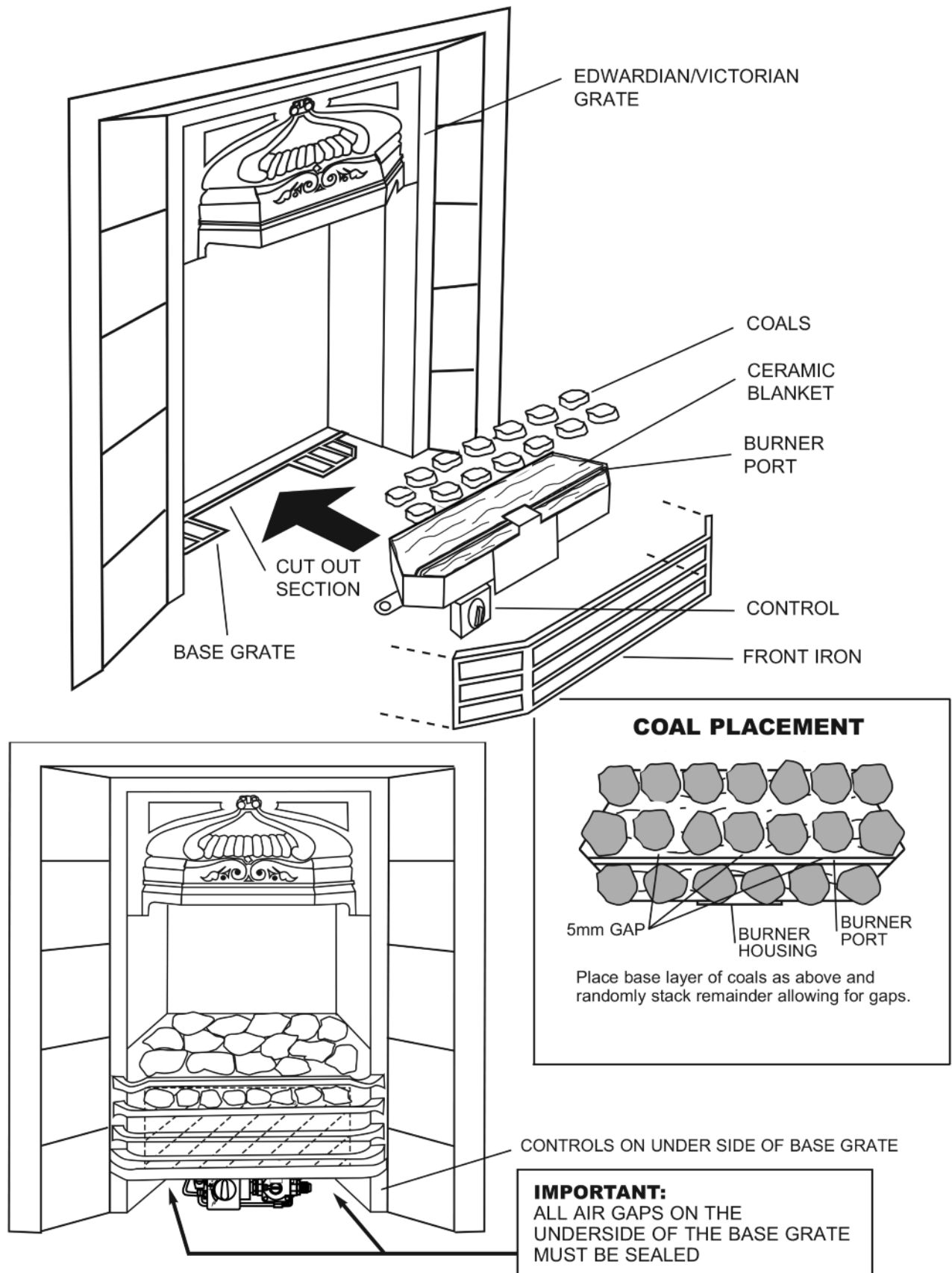

- Minimum insert depth 180mm.
- Maximum insert opening 675mm.

USER INSTRUCTIONS

1. Your Magiglo Gas Log/Coal Set will have been installed by an authorised person in accordance with the Installation and Service Instructions. If you are technically minded you will increase your knowledge of your fire by reading through these Instructions
2. Initially your Magiglo may burn with a slightly blue flame which part of the protective coating on the coal and logs burn off. A slight smell may also be apparent at this stage. After an hour or so the fire will have settled down and will therefore burn with a yellow flame producing a little soot. The soot deposit enhances the real effect and is exactly the same as an authentic fire.
3. As with all gas appliances, your Magiglo should be regularly serviced. We would recommend once each year. The name and address of your service technician can be obtained from your Real Flame stockist. The routine to be followed by the engineer can be found under Service Instructions; contained within this leaflet.
4. For safe operation of your Magiglo the following annual checks should be carried out.
 - Confirm that the chimney remains clear and unobstructed and there has not been a build-up of soot which would necessitate the chimney being swept.
 - Confirm that the room ventilation remains adequate and that all vents are free of obstruction.

TROUBLESHOOTING

Symptom	Corrective Action
Pilot won't light	<ol style="list-style-type: none"> 1. Pressure too low. Set to correct pressure. 2. Check for spark at electrode if none, check lead connection. If not solved replace electrode.
Pilot lights but does not stay on.	Light pilot and keep knob depressed for 30 seconds before releasing. If pilot does not stay on, replace thermocouple.
Main flame goes out or very little flame.	<ol style="list-style-type: none"> 1. Check for correct pressure. 2. Check for faulty thermocouple. 3. Excessive draught can cause flame to extinguish.

WARNING

The Magiglo burner burns with a real flame which should be treated with the same respect as any naked flame. A fireguard should be used for the protection of children and the elderly.

CONVERSION DETAILS

APPLIANCE AVAILABLE IN NATURAL GAS ONLY

PARTS LIST

PART No.	DESCRIPTION	PART No.	
01	Negabhan Control Valve	05	1/2" to 3/8" Hex Nipple
02	Regulator	06	5/16" 90O Union Elbow
03N	S.I.T. ODS Pilot Assembly (Natural Gas)	07	1/4" Nut and Olive
03P	S.I.T. ODS Pilot Assembly (Propane Gas)	08	Injector Holder Stem
04	1/2" Male to 1/2" Copper Union	09	Injector

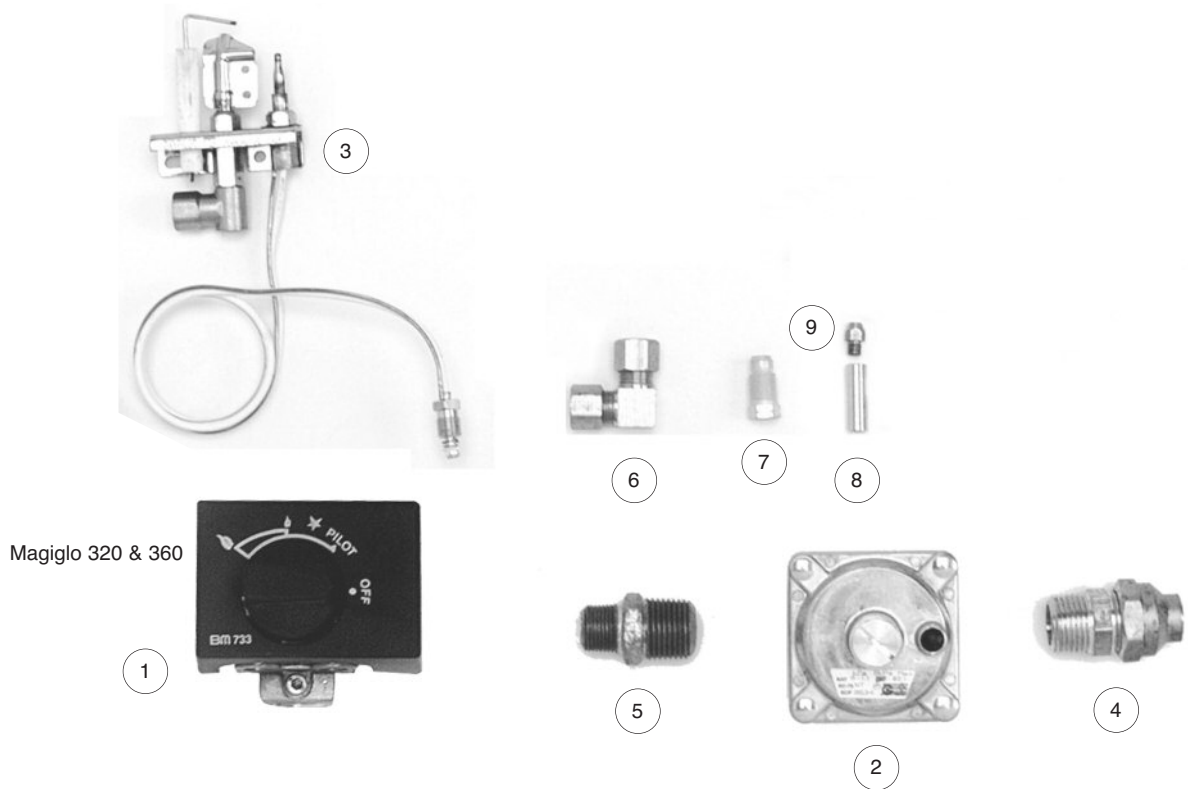

COAL SET





GLEN DIMPLEX AUSTRALIA PTY LTD

ABN 69 118 275 460

Head Office/Factory/Showroom

1340 Ferntree Gully Rd.

Scoresby Vic 3179

Ph: (03) 8706 2000 Fax: (03) 8706 2001

E-mail: info@realflame.com.au

Richmond - VIC Showroom

300 Swan St.

Richmond Vic 3121

Ph: (03) 9428 4443 Fax: (03) 9428 4445

Dandenong - VIC Showroom

3/328 South Gippsland Highway,

Dandenong South Vic 3164

Ph: (03) 9702 7853

E-mail: sales@realflamedandenong.com.au

Geelong - VIC Showroom

1/2A Gordon Avenue

Geelong West Vic 3218

Ph/Fax: 5229 0844

E-mail: info@realflamegeelong.com.au

Sydney - NSW Showroom

546 Pacific Highway.

Chatswood NSW 2067

Ph: (02) 8905 0189 Fax: (02) 8905 0192

E-mail: info@realflame.com.au

Miranda - NSW Showroom

36 Kareena Rd

Miranda NSW 2228

Ph: (02) 8513 6202 Fax: (02) 9520 1974

E-mail: fireplace@realflamesouth.com.au

Adelaide - SA Showroom

173 -175 Magill Rd.

Norwood SA 5067

Ph: (08) 8132 0371 Fax: (08) 8132 1687

E-mail: realflamesa@iprimus.com.au

Milton - QLD Showroom

46 Douglas St,

Milton QLD 4064

Ph: (07) 3368 2011

Perth - WA Showroom

47-53 McDonald St East,

Osborne Park WA 6017

Ph: (08) 9444 9900 Fax: (08) 9444 9800

Fyshwick - ACT Showroom

88 Wollongong St,

Fyshwick ACT 2609

Ph: (02) 6280 5522

Ulverstone - TAS Showroom

31A Victoria St,

Ulverstone TAS 7315

Ph: (03) 6425 4440