

**ETLIS 12 AND 8 ETHANOL FIREPLACE
INSTALLATION AND OPERATIONS MANUAL**

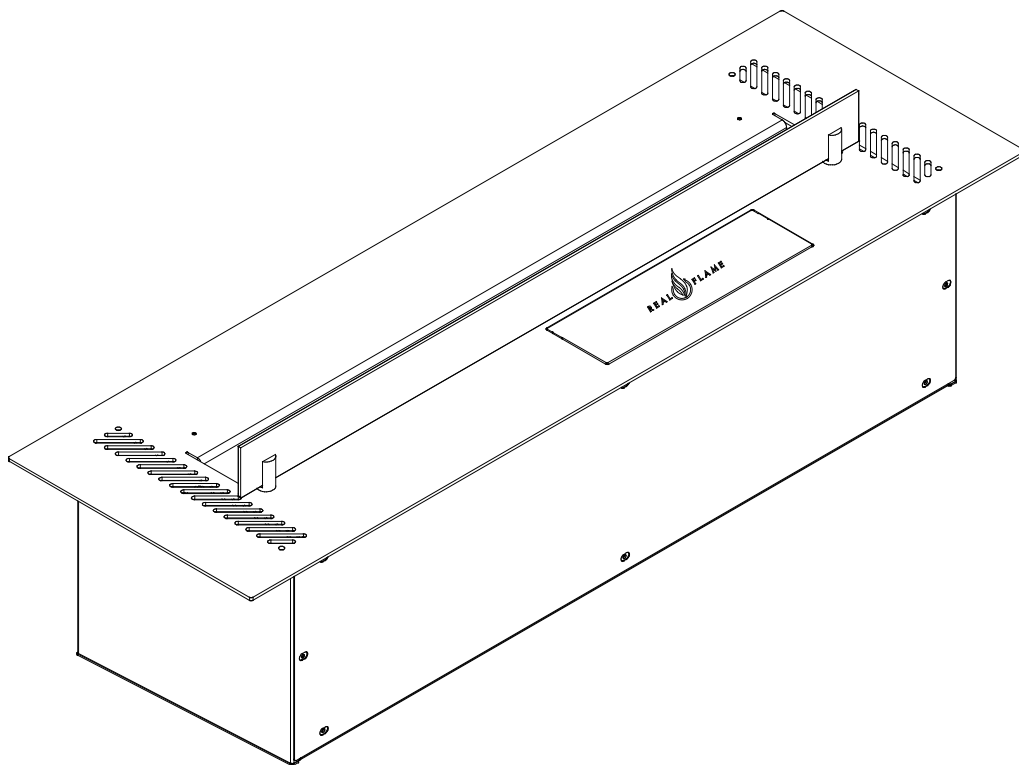

WARNING

This manual only applies to the installation and operation of Etlis burner only. The installation of the fireplace surround is in another manual distributed inside the surround packaging.

Consumer safety information: please read this manual before installing and operating this appliance. Failure to follow these instructions may result in a possible fire hazard and/or injury and will void the warranty



The product is a decorative device creating real fire.
Read the included documentation prior to installing and operating the device.
Check the local regulations for fireplaces and fuel storage



1. For indoor use and in housing only. Min. temperature of use is 10°C.
2. Natural air exchange rate in room – min. 1/h.
3. Do not use the device in humid and drafty spaces.
4. Do not cover top ventilation openings of the device.
5. No heat-sensitive and flammable objects can be placed within a 1 meter radius from and directly above the device.
6. Only use manufacturer-approved decorative accessories for fireplaces. Follow the provided guidelines to prevent damage to the unit.
7. Only use the plugs/electrical cords supplied with the fireplace.
8. We recommend placing a CO2 or dry powder fire extinguisher nearby the device
9. For service purposes, the surrounding must allow for easy removal of the device.
10. Keep children, animals and unauthorized persons away from the device.
11. Please keep the product packaging for the duration of the warranty period. The packaging may be necessary in case the product needs to be returned, exchanged or repaired.
12. Do not turn on the device in case of fuel spill.
13. Do not interfere in the fuel filler when the device is operating.
14. Do not interfere in the device construction.
15. Do not touch the filament and other hot elements.
16. Do not transport the device if fueled.
17. Do not leave an operating device unattended
18. Any spillage should be thoroughly wiped up before igniting the unit.

NOTE: A slight smell may be apparent for the first few hours of use. This is due to the heat-resistant paint curing. It is recommended to open windows in the room for the first lighting of the fire. In some instances, a slight discolouration may occur inside the firebox. This is a normal condition and is not covered by warranty.

WARNING For protection of young children or the infirm, a secondary guard is required.

The appliance is not intended for use by persons (including children) with reduced physical, sensory or mental capabilities, or lack of experience and knowledge, unless they have been given supervision or instruction concerning use of the appliance by a person responsible for their safety. Children should be supervised to ensure that they do not play with the appliance.

The glass panel gets extremely hot! Precaution should be taken and young children supervised at all times when the heater is operating.

The use of an extension lead or multi-plug adaptor is not advised when connecting this product to the mains. Connection through these devices could lead to a risk of overloading, overheating and even fire at the extension lead or adaptor due to inadequate connection quality.

“**WARNING** - Transit material such as cardboard packaging, pallet, plastic wrap, glass packaging warning labels and burner media protection must be removed prior to use.”

IMPORTANT SAFETY NOTICE Do not place articles on or against this appliance.

Do not use or store flammable materials in or near this appliance.

Do not spray aerosols in the vicinity of this appliance whilst it is in operation.

Care must be taken to ensure that any return air register or exhaust system does not adversely affect the operation of the appliance or draught of chimney or flue.

Do not modify this appliance.

SERVICING It is recommended you service your fire every 2 years as a minimum.

CORD REPLACEMENT Electrical cord replacement must be undertaken by qualified and trained personnel only. If the supply cord is damaged, it shall be replaced by the manufacturer or its service agent or similarly qualified person to avoid any hazards.

WARNING Appliance must be earthed.

Burner	L [mm]	D [mm]	H [mm]	Minimum Room Size [m ³]	Heat [kW]
890	890	280	216	44	4,4
1290	1290			94	9,4

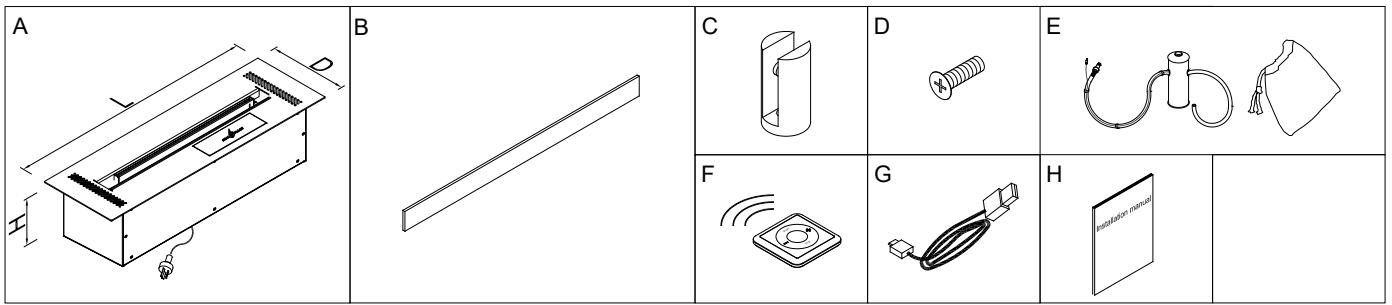

	Items	Quantity
A.	Burner	1
B.	Glass shield	2
C.	Small glass holder	4
D.	Glass holder connector	
E.	Fuel pump	1
F.	Remote control	1
G.	Service cable	1
H.	Installation and user's manual	1

ELECTRICAL CONNECTION- 3 Pin 10 Amp GPO plug

POWER RATING OF APPLIANCE - 230V 50Hz 3.6 Amp

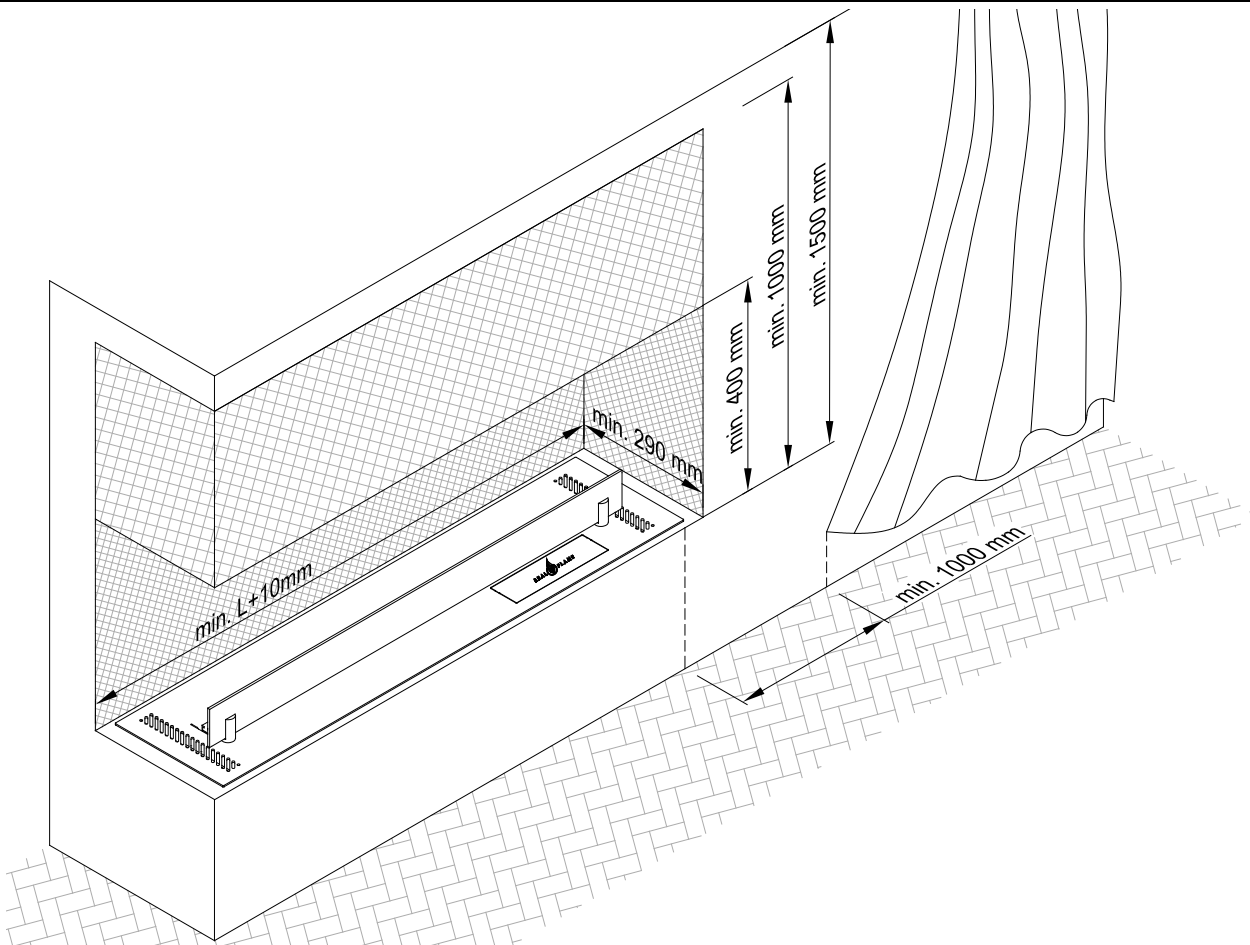
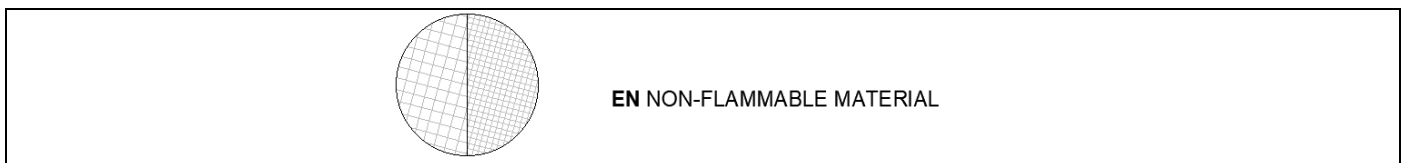

NOTE The fireplace surrounding must be made of non-flammable materials and insulated from any flammable elements of the construction. Use only fasteners and adhesives that are resistant to high temperature.

1.

The space under the device must be closed.

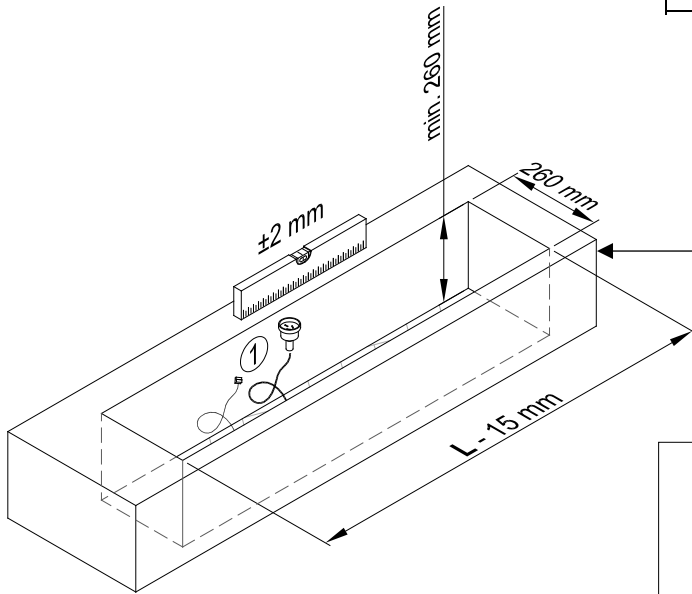

①

Min. 3x1,5 mm², 230 V, 50 Hz,
PE

Optional SHS connection

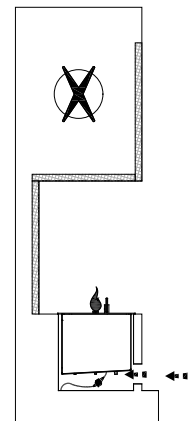
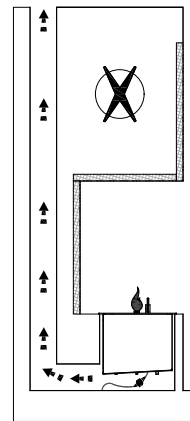
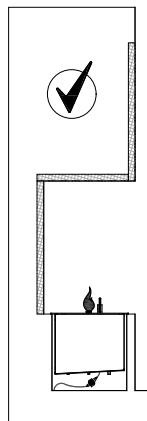

2.

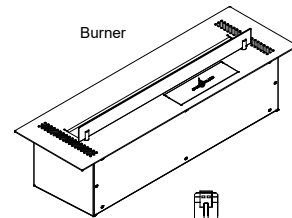
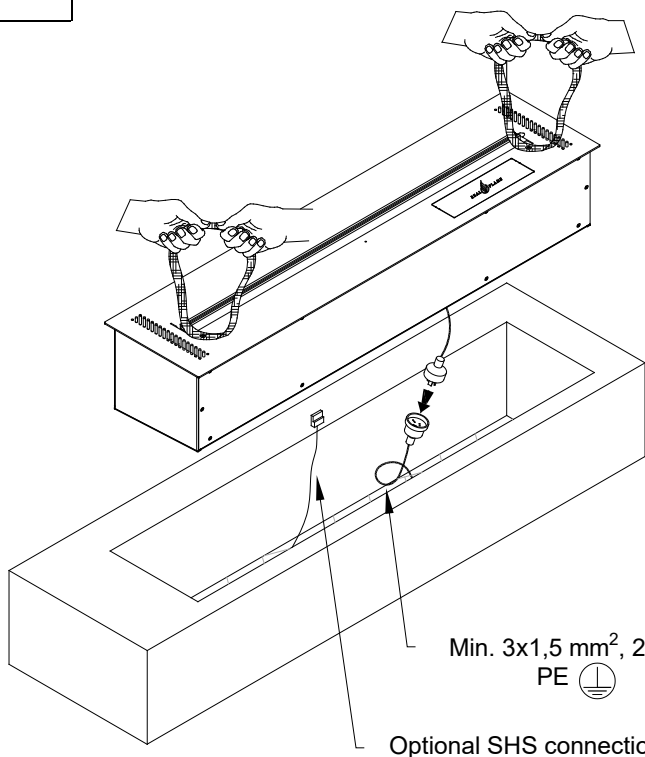

RJ45 Ethernet
(not supplied by producer)

SHS module

Device control signal
(Potential / Potential Free)
(not supplied by producer)

Input / Output Connection
(not supplied by producer)



Smart Home System

EN Installations with back wall. Glass shield is obligatory.

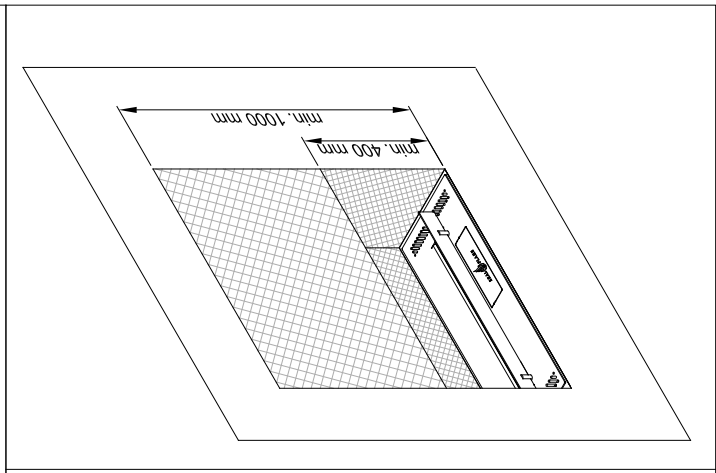
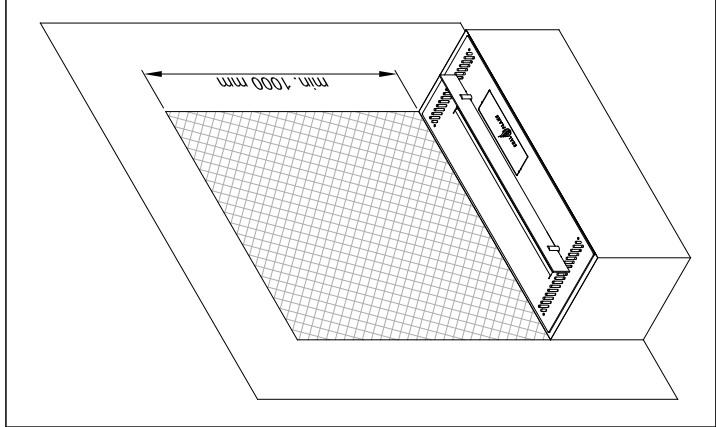
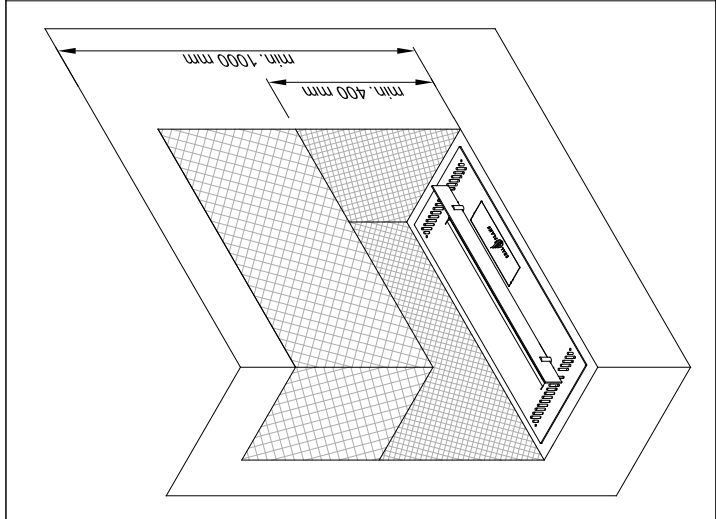
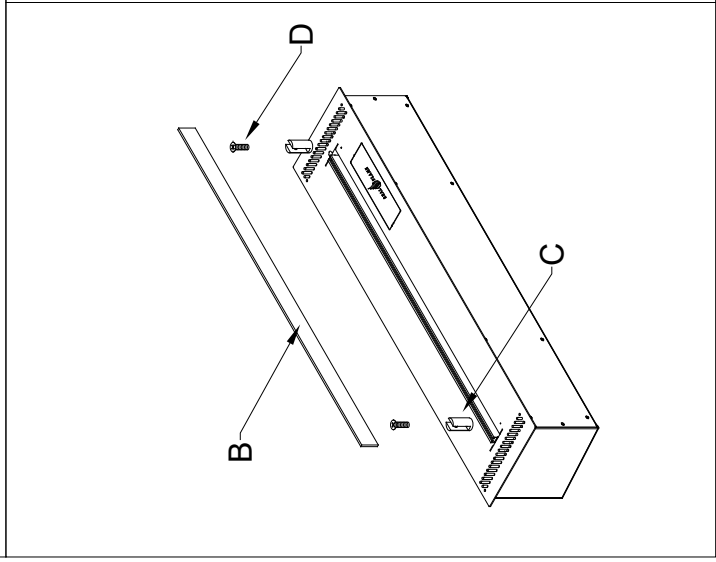
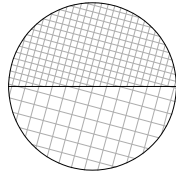
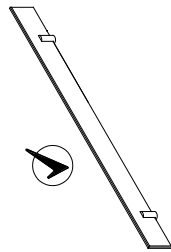

EN Two side open installations (without back wall). Tall glass panels option, fireplace without glass shield.

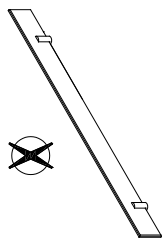

EN GLASS SHIELD (B)

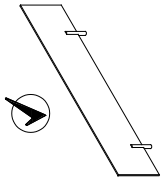

EN OPTIONAL TEMPERED GLASS PANEL

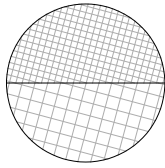

EN NON-FLAMMABLE MATERIAL

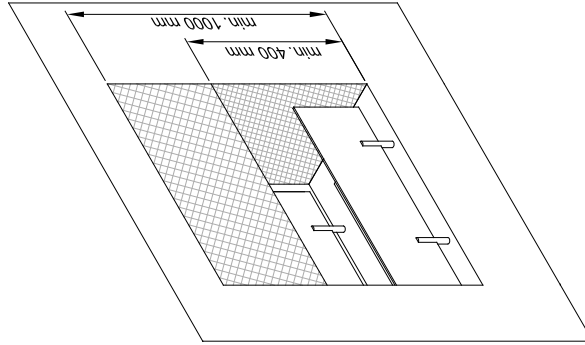
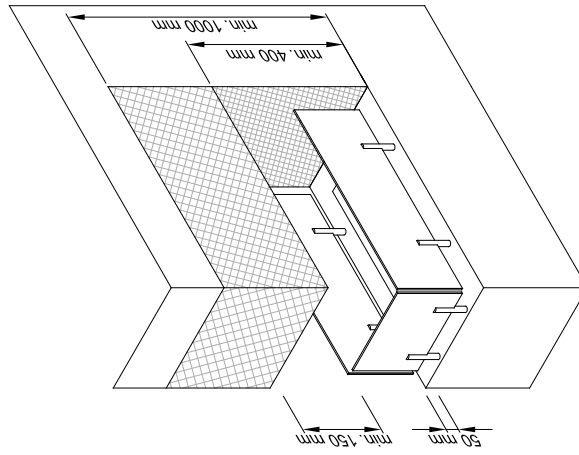
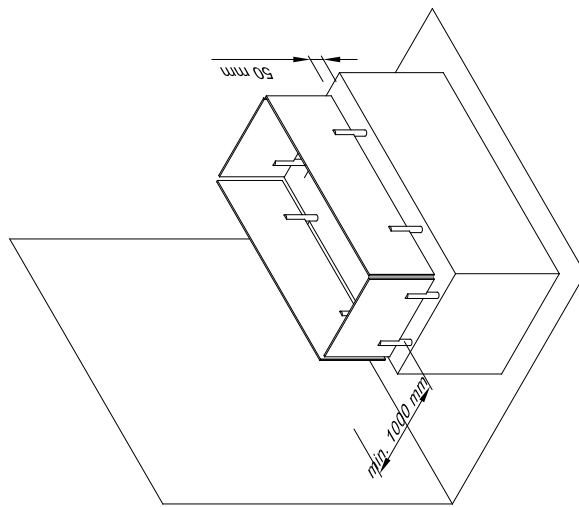

EN Two side open installations (without back wall). Frame with glass screens option, fireplace without glass shield.

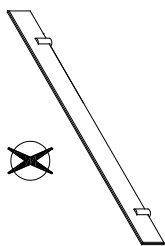

EN GLASS SHIELD (B)

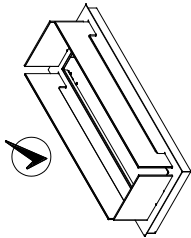

EN FRAME WITH GLASS SCREENS

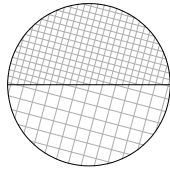

EN NON-FLAMMABLE MATERIAL

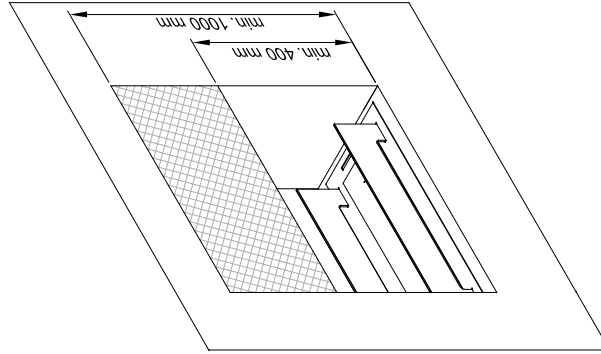
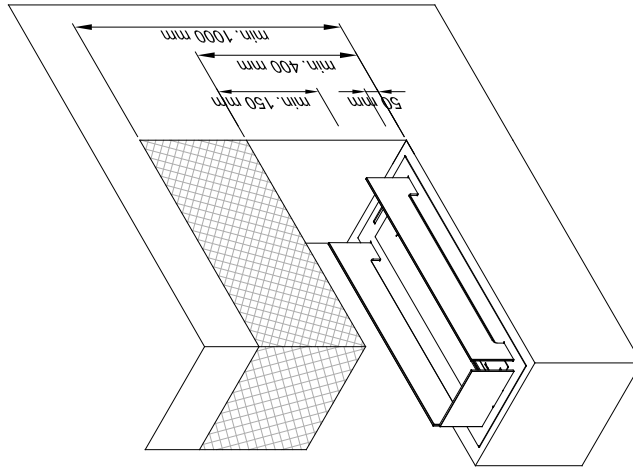
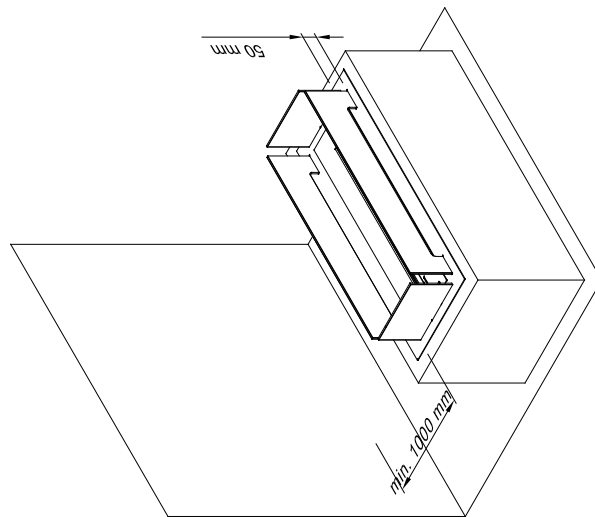

EN Two side open installations (without back wall). Fireplace with double glass shields option.

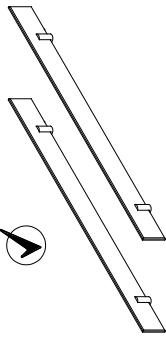

EN GLASS SHIELD (B)

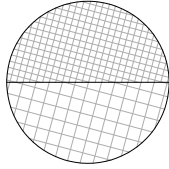

EN NON-FLAMMABLE MATERIAL

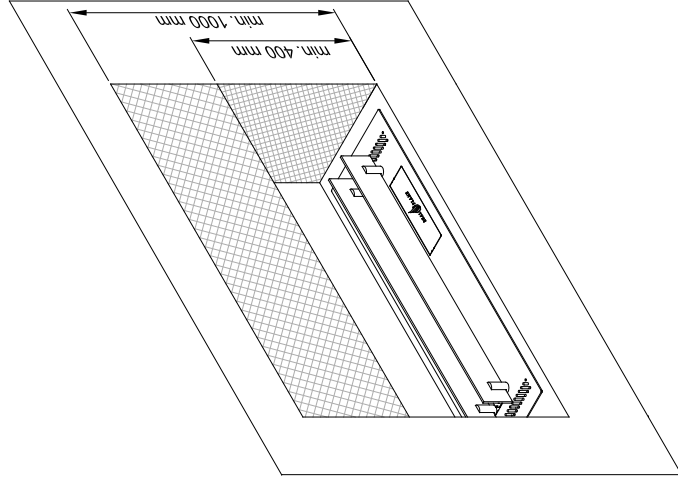
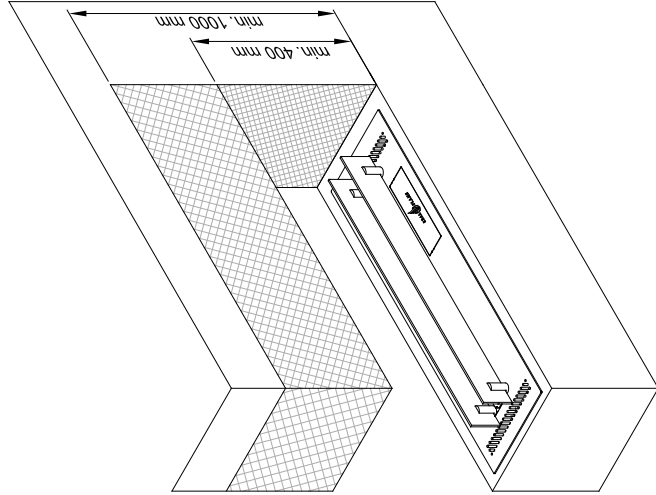
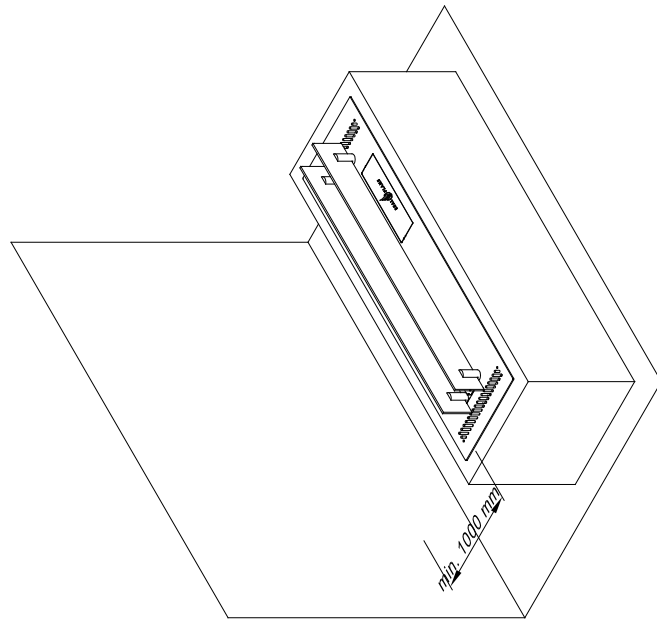

TV

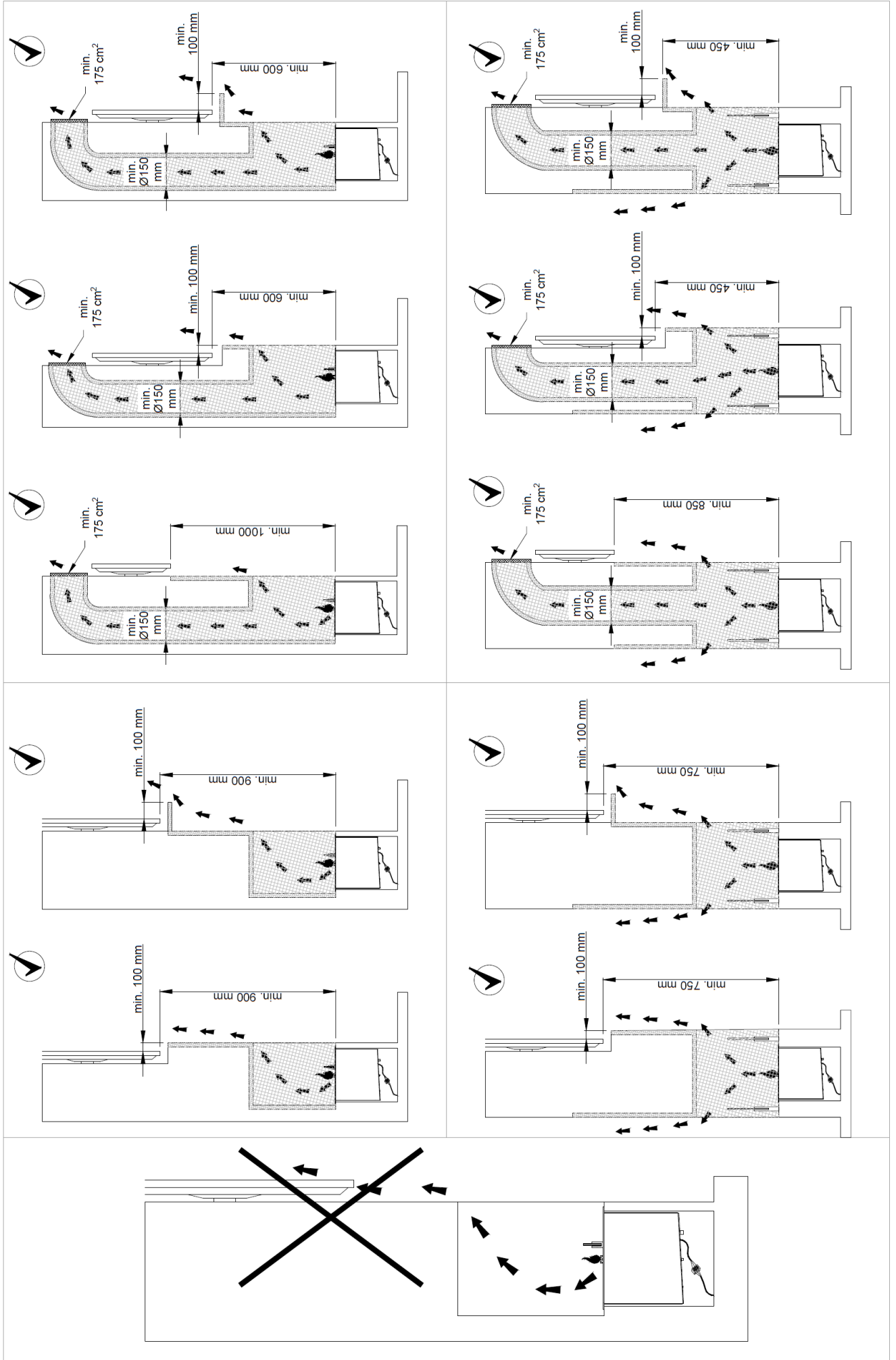

TV

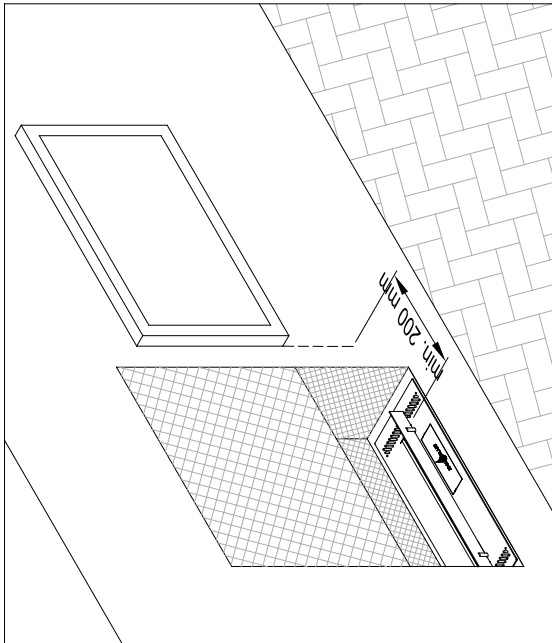
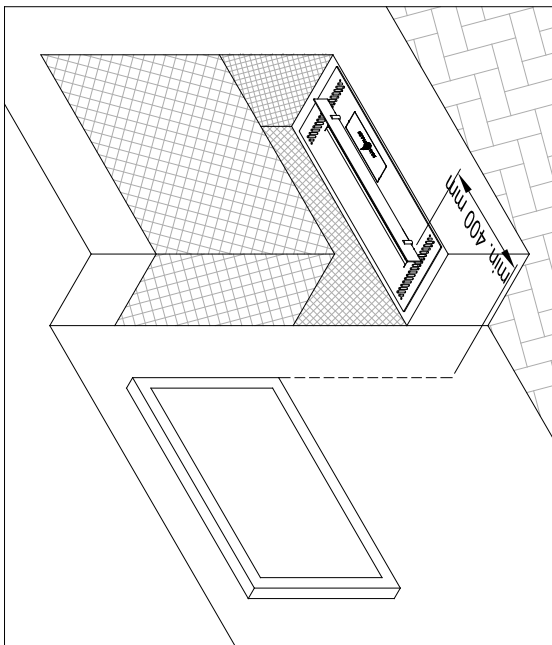

AC

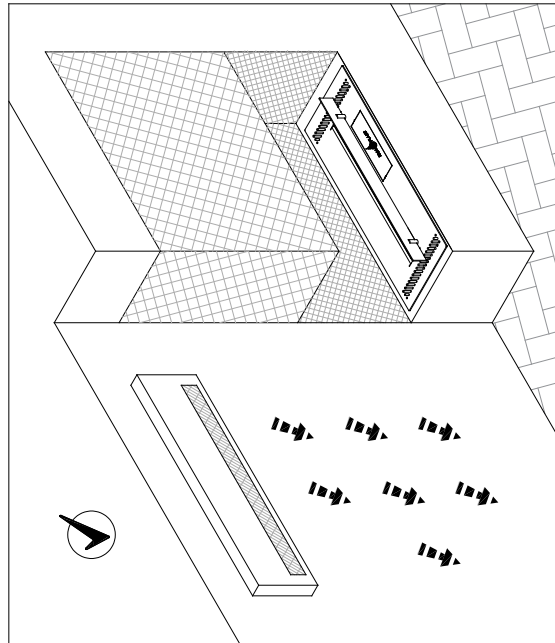
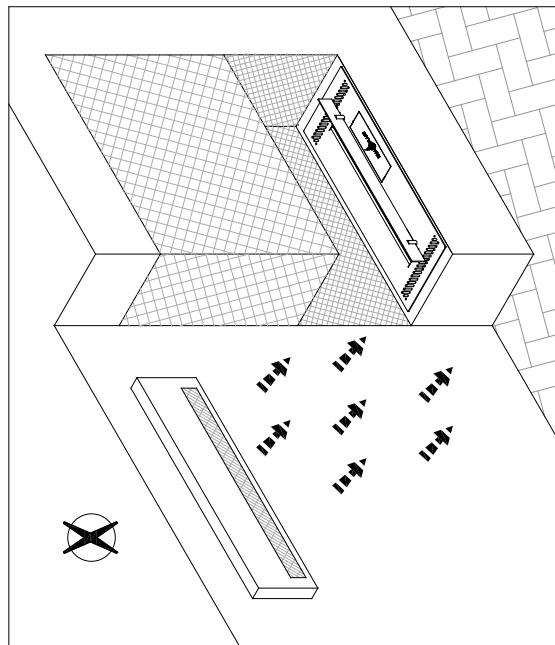

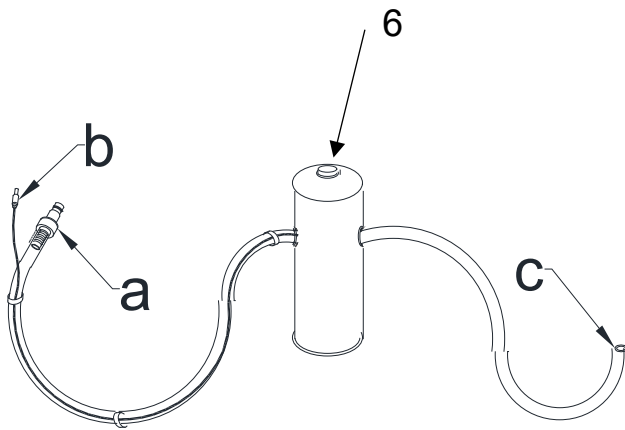
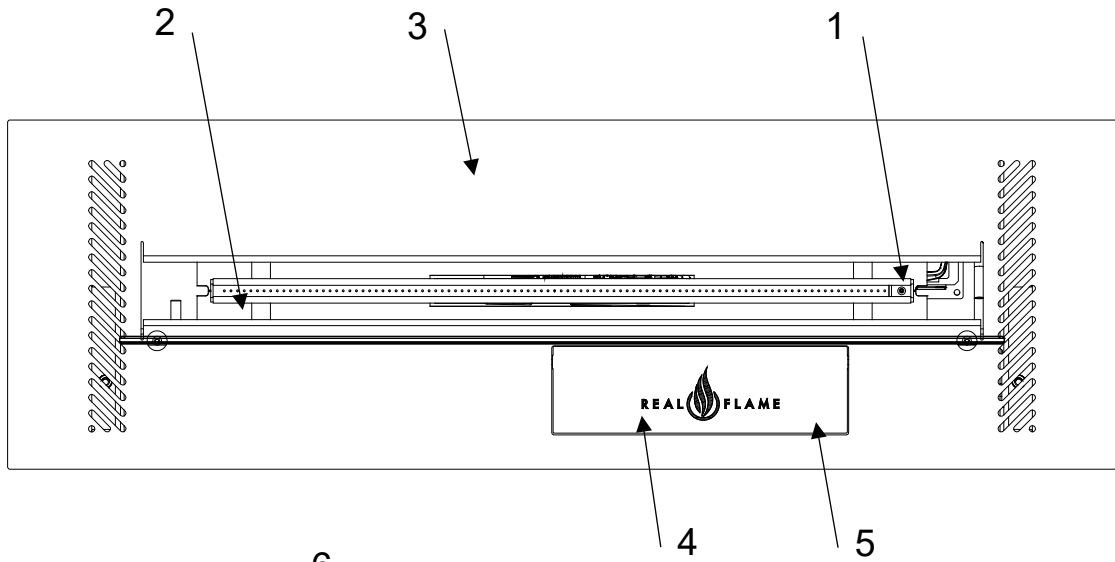

- | |
|---|
| <ol style="list-style-type: none"> 1. Filament 2. Burner 3. Device surface 4. Control panel 5. Fuel filler 6. Fuel pump (a, b, c) |
|---|

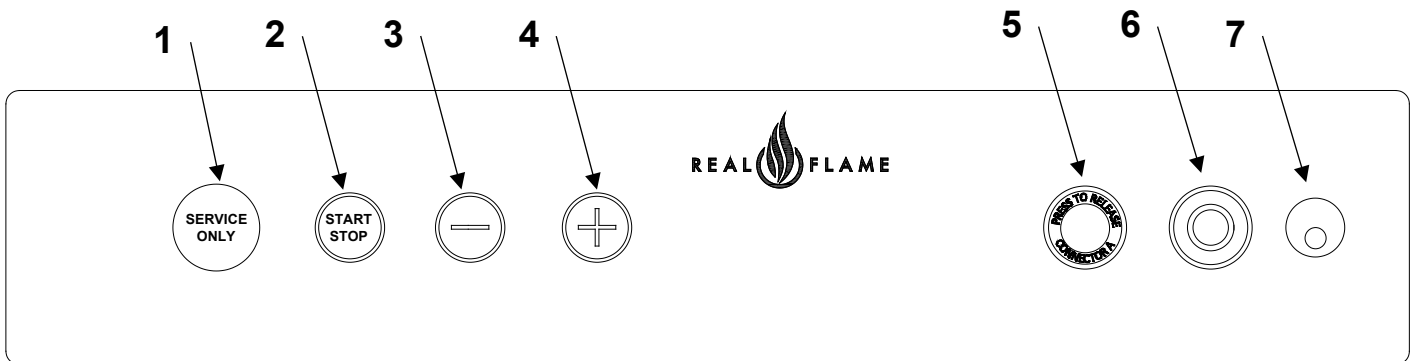

- | |
|--|
| <ol style="list-style-type: none"> 1. Service port 2. Power ON/OFF 3. Decrease flame level 4. Increase flame level 5. Fuel pump release 6. Fuel pump coupling 7. Fuel pump power socket |
|--|

REFUELLING

1. Open the lid (I)
2. If the fuel tank is empty (**START/STOP BUTTON BLUE LIGHT ON**) or you want to refuel the fireplace, firmly plug in the fuel pump inlet 'a' (you will hear a click sound) and the power cord 'b' (II) (**BLUE LIGHT FLASHING**).

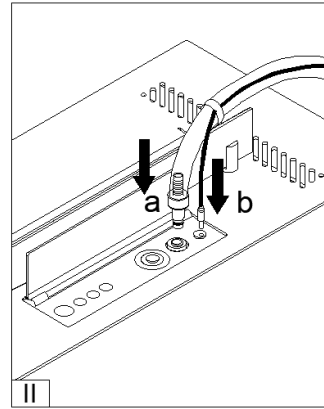
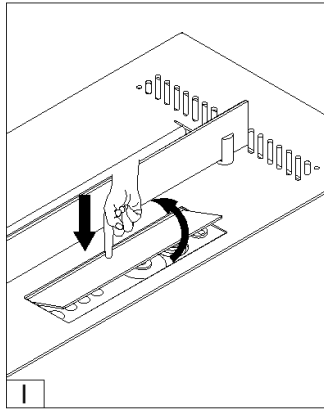

3. If the fuel bottle is secured with the flame restrictor (cap on the bottles' neck) (III) please remove it before inserting the fuel pump inlet (IV) Place the fuel container stably on the floor and insert the pump hose 'c' (IV). Press and hold the button on the pump to start refuelling (V).

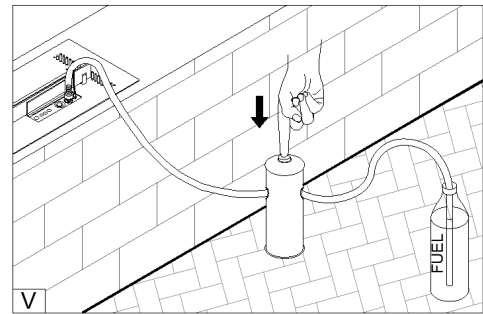
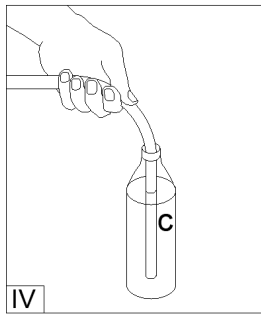
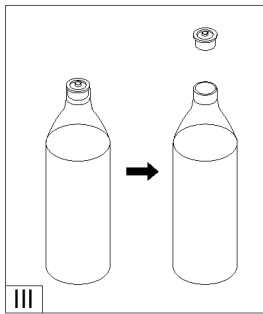

When the fuel bottle is empty, replace it with a full one and continue using the pump (see: section 3 above). The pump will stop refilling when the fuel tank is full (you will hear a beep).

4. Unplug the power cord 'b'. To unplug the pump, hold the pump inlet 'a' and firmly press the release button (VI).
5. Shake the remaining fuel from the hose 'c' to the container and place the pump in the bag (VII).

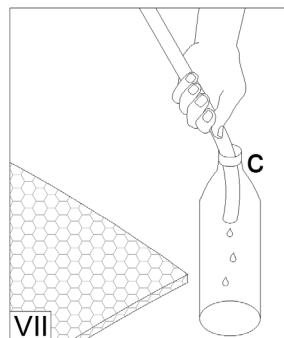
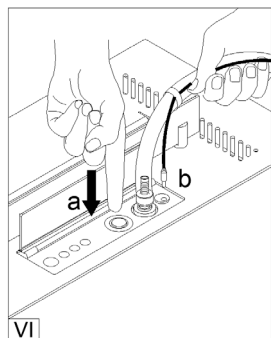



FLAME IGNITION

When the **START/STOP** button is lit up in green, the device is ready to be launched.

Press **START**. Firing up of the device takes from 2 to 10 minutes (**FLASHING GREEN LIGHT**). During the process of firing up, scent of fumes can be present. When the lights stop flashing, the device is lit up and has reached the working temperature.

FLAME HEIGHT REGULATION

When the flame is fired, press  or  on the remote control / move the flame height bar in the app or press + / - on the control panel to increase or decrease its height in 3 levels.

NOTE. In case of too high a temperature of the device, the flame height will be automatically decreased and locked from changing. If the temperature continues to increase, the flame will be extinguished (**RED LIGHT**)

FLAME EXTINGUISHING

To extinguish the flame:

-press **STOP**. When the flame is being extinguished, additional fans are turned on to speed up the cooling process.

Red light indicated the device being cooled. Restarting the flame is possible only after complete cooldown of the device (**GREEN LIGHT**).

FAST START

The **FAST START** function enables the flame to be fired more quickly (power consumption in **READY** mode is approximately 60 W more). The function is enabled by default.

To deactivate **FAST START**, press the - button for 10 seconds. To reactivate the function, press the + button for 10 seconds when the fireplace is in **READY** mode.

WIRELESS CONTROL CONFIGURATION

The fireplace can only be paired when it is in **READY** mode (**START / STOP** highlighted in green)

To pair the device with the mobile app (simultaneous pairing of more than one device is not possible):

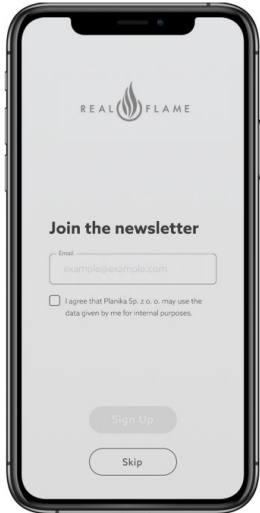
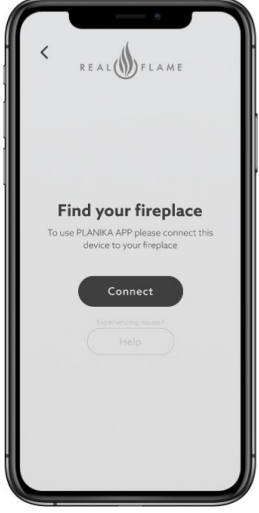
<p style="text-align: center;">Join the newsletter</p> <p>1. Launch the bioFlame Connect mobile app. Join the newsletter by submitting your e-mail address and pressing SIGN UP or simply press SKIP.</p>		<p style="text-align: center;">Find your fireplace</p> <p>2. On the FIND YOUR FIREPLACE screen press CONNECT to start the network search.</p>	
---	--	--	--

3. Press and hold the + and - buttons on the fireplace until the + LED blinks blue. If there is no activity the standby will be cancelled after 5 minutes.

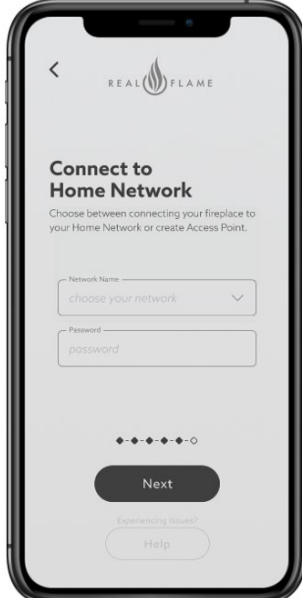

<p style="text-align: center;">Setup Network Active</p> <p>4. Go to mobile device setup, turn on the WiFi network and connect with Fireplace_WiFi_setup (If the network is not visible, disconnect the power to the device for 10 seconds and repeat the configuration). Return to the application and click NEXT. The fireplace will be automatically found by the mobile app, which will be confirmed by the app (SETUP NETWORK ACTIVE). Press CONNECT.</p>		<p style="text-align: center;">Connect to Home Network</p> <p>5. On the CONNECT TO HOME NETWORK screen, choose the name of the network which you plan to use by default (NETWORK NAME) and submit its password. Make sure the password is correct and hit (NEXT).</p>	
--	---	---	---

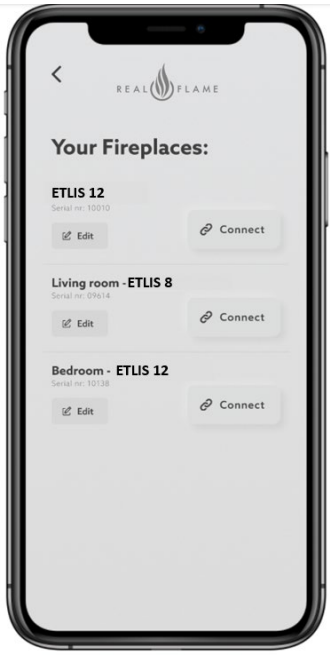
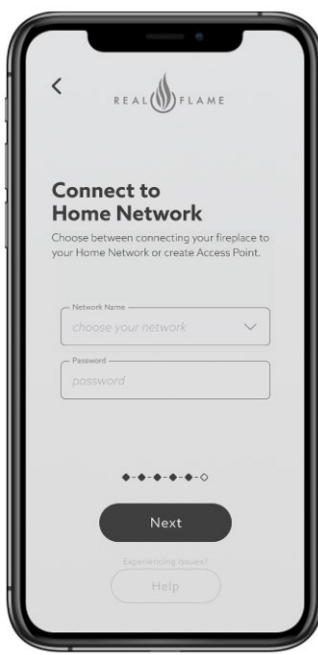

Your fireplaces		Access Point	
<p>6. On the following screen (YOUR FIREPLACES), choose your device and press CONNECT. The screen also allows you to change the name of the fireplace (EDIT).</p>		<p>7. You can also create a dedicated network ACCESS POINT and connect directly with the device. To do that, press (HELP), choose (CONNECTION TYPE), and (ACCESS POINT), then confirm by pressing (CREATE ACCESS POINT). Submit new name for the network and the password. Confirm by pressing NEXT.</p>	

After successful configuration, the + LED will light up green



bioFlame Connect MOBILE APP

	<ol style="list-style-type: none"> 1. Newsletter (will only appear if you confirm when configuring) 2. Fireplace status 3. Fuel level 4. Flame height 5. Start and stop 6. Info 7. Menu
--	--

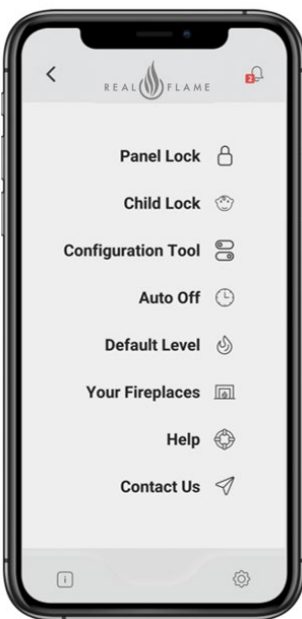

MENU

To access menu, press the  button. To go back to the main panel, press **BACK** 

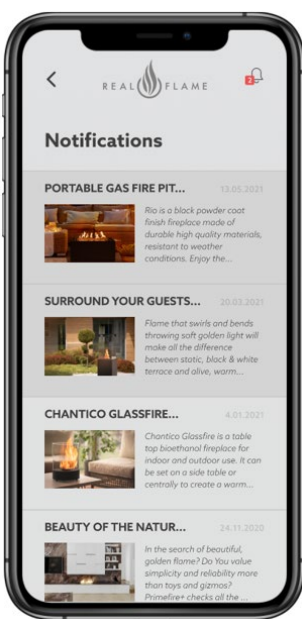
To access general information about the fireplace, press the  button. The newsletter is available after pressing the  button.

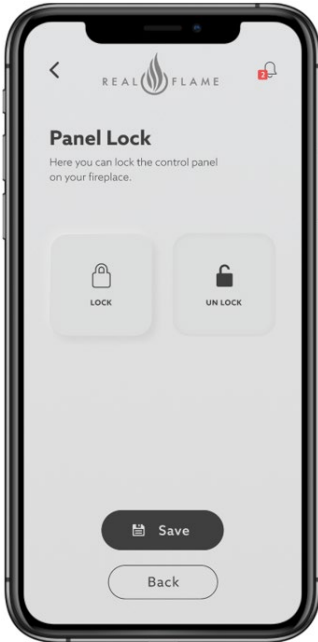
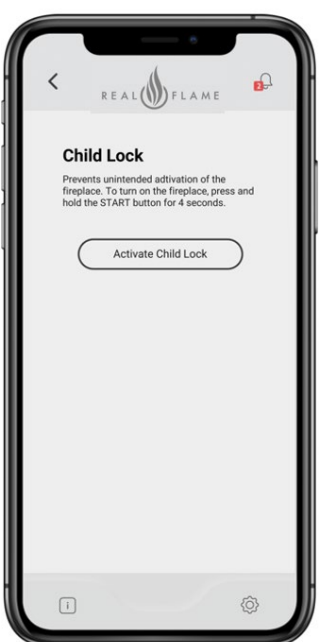
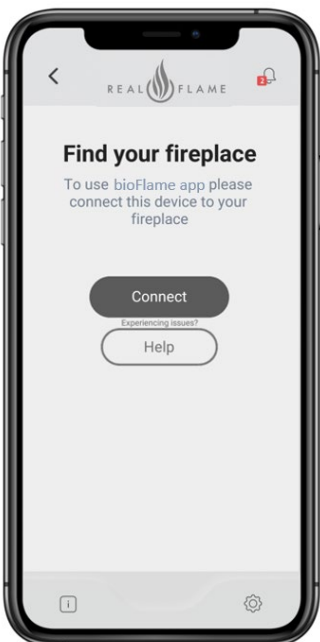
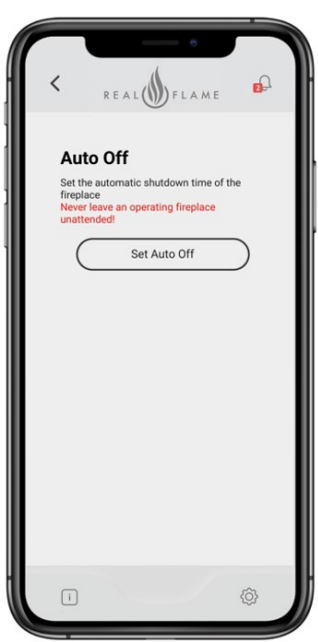
Menu	Info	Newsletter
		
<p>Main app setup. Press the tab to change the settings.</p>	<p>Press to check the general information of the fireplace</p>	<p>Press to check the notifications</p>

Panel Lock	Child Lock	Configuration tool	Auto off
			
<p>Press LOCK to lock the control panel on the fireplace. Press UNLOCK to unlock the control panel on the fireplace. Confirm by clicking SAVE. The change is possible with the fireplace off only.</p>	<p>Click ACTIVATE CHILD LOCK to activate the device lock.</p>	<p>Click CONNECT to add a fireplace.</p>	<p>Click SET AUTO OFF to activate the automatic switching off of the fireplace after a preset time.</p>

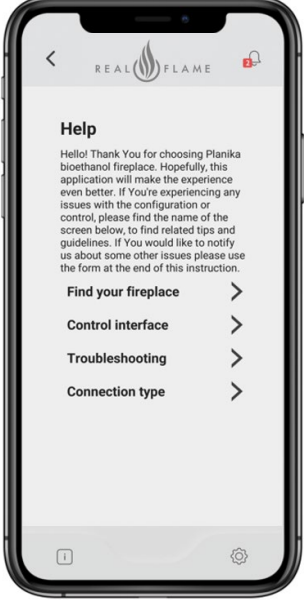
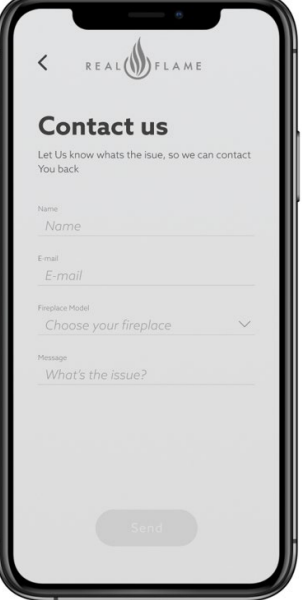
Default Level	Your fireplaces	Help	Contact Us
			
<p>Set the flame level at which the fireplace will start when it is switched on. Click SAVE to save your changes. RESET to reset the settings. The flame is factory set at level 2.</p>	<p>Check the available fireplaces. Click EDIT to edit the device name. Click CONNECT to connect to the appliance.</p>	<p>Click HELP in the main MENU to access other tabs.</p>	<p>Contact via email. Click SEND to send the message.</p>

ERRORS

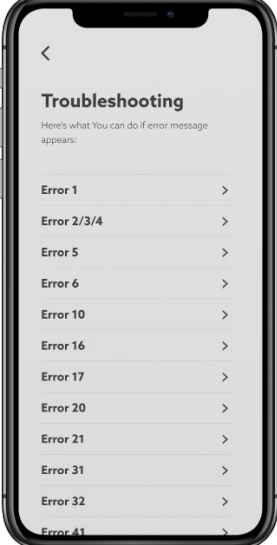
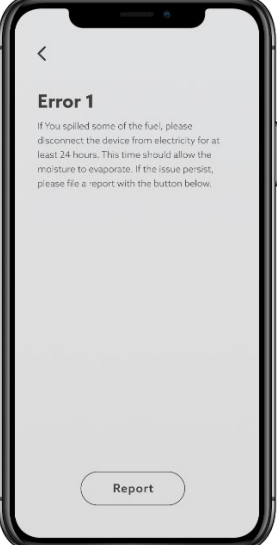
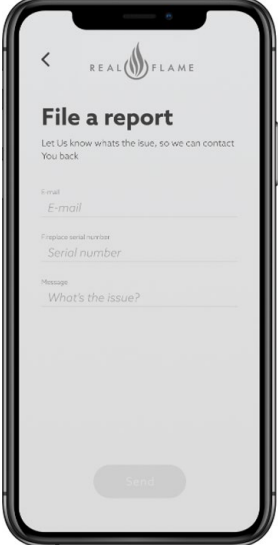
Troubleshooting	Error	File a Report
		
<p>Press HELP in the main MENU to access the Troubleshooting tab.</p>	<p>Fix the error with the provided information. If the error proceeds to appear, contact us by pressing REPORT.</p>	<p>If still in need of service, send us a message with a short description of the problem and general information. Press SEND.</p>

The error is indicated by a red lit button **START STOP** and blinking + and -. Each error is indicated by a number, the blinking - indicates decimals, the + indicates unities.

E.g. Error 21 will be displayed by blinking - twice and + once.

The message is repeated during the 10 sec cycle until it is switched off.

ADDITIONAL INFORMATION

FUEL - Use only ethanol fuel produced from plants in the process of two-time alcohol distillation consisting of 95-96.6% ethanol by volume. Fanola is the recommended fuel with pharmacological purity.
DO NOT USE SYNTHETIC PETROLEUM BASED FUELS AS THEY ARE CONTAMINATED, EMIT UNPLEASANT ODORS AND CAN DAMAGE THE FIREPLACE! DO NOT USE FUELS CONTAINING 100% ETHANOL BY VOLUME, GEL, OR AROMATIC FUELS!

CLEANING – Clean with a damp cloth and delicate detergents, only when the device is turned off and cooled.

WARRANTY INFORMATION

Warranty is provided in Australia by Glen Dimplex Australia Pty Ltd.

This limited warranty is provided to the first domestic purchaser of a Real Flame Ethanol fire. It applies from the date of purchase from or through an authorized Real Flame Ethanol Fire Distributor in any State or Territory of Australia and is not transferable.

Products covered by this limited warranty have been tested and inspected prior to shipment and, subject to the provisions of this warranty, Glen Dimplex warrants such products to be free from defects in material and workmanship for a period of 2 years from the date of the first purchase of this product. The limited warranty period also applies to any implied warranties that may exist under applicable law. Some jurisdictions do not allow limitations on how long an implied warranty lasts, so the above limitation may not apply to the purchaser.

What is covered under this warranty?

- Repair or replace product or parts of a defective Ethanol Fire
- In the event a repair or replacement is not commercially practicable or cannot be timely made, Glen Dimplex may, in lieu of repair or replacement, choose to refund the purchase price for such product or part.
- Labour costs relating to the Ethanol Fire.

Consumers may have additional rights under the Australian Trade Practices Act 1974 including the Australian Consumer Law or the Consumer Guarantees Act 1993 New Zealand.

This warranty does not apply and will be void where:

- The Ethanol Fire is not installed by a qualified specialist installer;
- Any electrical work has not been carried out by a Registered Electrician;
- The Ethanol Fire has been moved and reinstalled, or has been modified in a manner that is not consistent with the Installation Guide or the Owner's Manual;
- The Ethanol Fire has not been installed or operated according to the Installation Guide and the Owner's Manual;

What is not covered with the limited warranty?

- Labour costs relating exclusively to components not manufactured by Glen Dimplex.
- Labour costs relating to removing or replacing the Ethanol Fire
- Damage caused by incorrect use of the Ethanol Fire.
- Products that have been repaired (except by Glen Dimplex or its authorised service representatives) or otherwise altered.
- Travel costs for a distance greater than 50 km from the nearest approved Service Agent.
- Defects, malfunctions or failures caused by incorrect installation, poor installation, normal wear and tear, misuse, neglect, accidental damage or failure to follow operating instructions in the Owner's Manual (including incorrect power source, product operation and maintenance instructions), repairs or modifications by persons not authorised by Glen Dimplex, use of parts not supplied by Glen Dimplex, or damage or other events which have occurred since the product left the control of Glen Dimplex.
- Installation of the Ethanol Fire in an outdoor setting.
- Removal or transportation of such product or part (and any repaired or replacement product or part) to and from the authorized dealer's or service agents place of business.
- On-Site or In-Home services; these services may be performed at the purchaser's request and expense at Glen Dimplex's then-current rates for such services.
- Direct, indirect or consequential losses or special damages of any kind (including costs of collection and delivery) other than repair or replacement of products or components under this warranty, where any goods are acquired or used for the purposes of a business.

How to obtain warranty service?

- Product registration via the website (realflame.com.au) must be completed within 30 days of purchase or your Gas Burner, or within 30 days of the date of settlement of purchase of a new home.
- Warranty Claims must be made at place of purchase.
- Reasonable proof of purchase date is required to make a warranty claim. You should keep your purchase receipt.
- Warranty repair will be completed according to normal work practices of the service agent.

Make the faulty part(s) available to Glen Dimplex for inspection so that the validity of the claim can be established by them.



Website:
www.realfame.com.au

Telephone:
1300 554 155

© Glen Dimplex.
All rights reserved. Material contained in this publication may not be reproduced in whole or in part, without prior permission in writing from Glen Dimplex.
All technical information provided herein is subject to revision based on any technical updates.